



**WESTERN
OREGON
CONTROL
LINE
FLYERS**

THE WOLF CALL

July - August - September 2017

**ACADEMY OF MODEL AERONAUTICS
CHARTER CLUB #3464**

Upcoming Local Events

Sept. 2nd Zoot Ranch Fun Fly

Sept 23 & 24 NW CL Speed Champs

The "WOLF CALL" is the newsletter for the Western Oregon Control Line Flyers. WOLF members fly at the Bill Riegel Model Airpark facility at the Salem Airport.

WOLF membership is not required to utilize the facility, but fliers should be A.M.A. members. If you are not a WOLF club member, please consider joining us to help support control line model aviation activity in our area.

WOLF CLUB OFFICERS:

President: Craig Bartlett

Vice-President: Dean Singleton

Secretary-Treasurer: Mike Hazel

Safety Officer: John Thompson

Newsletter: Mike Hazel

For the latest Northwest Control Line news go to:

flyinglines.org

Miscellaneous Ramblings from Ye Olde Editor

Greetings All! Summer finally arrived, and it did so with a vengeance! This is definitely one of the warmer and drier ones that I can remember.

Lots of activities coming up, so check out the information within these pages and plan accordingly. One addition is a late season fun fly we will have at our field. Details are tentative at this point, one variable being what the "grass" circle condition will be by then. Sometime soon we will need to get together a work party and clean it up as needed.

We received the following bad news on July 2nd

Dear Fellow Club Members,

I regret to inform you that on the evening of July 2nd my wife Alice Cotton-Royer was struck by a Nissan Frontier pickup truck while riding her Razor Metro electric scooter. She was on her way home from helping an injured friend for the day. She is at the Legacy Emanuel Hospital recovering from a very serious leg injury along with multiple facial fractures. The trauma unit is taking very good care of her. She will be in hospital for some time as numerous operations will be necessary to repair her leg. How much surgery will be required to repair her face can not be determined until the swelling is reduced. I'm asking for prayers for her recovery.

Also, if anyone can recommend a Personal Injury Lawyer that they have had a positive experience with I would greatly appreciate a referral.

Regards, Dave Royer

Your thoughts and prayers for Alice would be appreciated. Last word is that Alice is still in recovery unit.

Question of the month.....

Why does "fat chance" and "slim chance" mean the same thing?

On the Contest Trail.....

Plenty of action in the Northwest contest scene the last few weeks.

The "big one" aka the Northwest Regionals took place in Roseburg on May 26 thru 28. The weather was outstanding this year, could not have asked for better conditions. Lots of WOLF members are involved in putting this event on plus competing in it as well. For full details please check out the excellent report on the Flying Lines website.

Next up was the traditional "Stuntathon" meet put on by the NW Skyraiders gang. For various reasons, the turnout was pretty low. Fred Underwood took top honors in the profile stunt class, and it was good to see Jerry Eichten return to action snagging third spot.

Up Canada way the Western Canada Stunt Championships took place on July 30 & 31. No WOLF members participated in that event.

The traditional Bladder Grabber combat contest was on August 11 thru 13. WOLF members Gene Pape, John Thompson and Gary Harris participated. Ye Olde Editor had to sit it out for this year. Two combat events are flown: high performance 1/2 A, and "Fast". John took second place in the 1/2 A event.

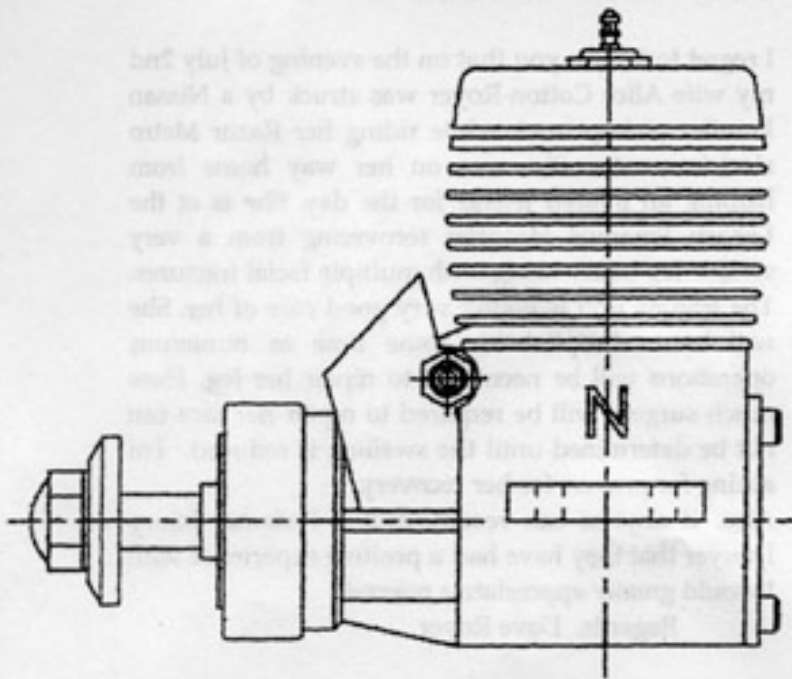

COMBAT ENGINES:

Here are a couple of the popular combat engines that were seen at the recent Bladder Grabber contest.

On this page is a full size rendition of the Nelson 36 combat engine. This thing is a real fire-breather, but no need to tip the nitro can for performance with it. Most fliers typically use 15% nitro with it. And these engines are quite reliable and do last.

On the neighboring page is the Cyclon 049, which is shown full size from a drawing I made when the engine was relatively new. The Cyclon is now hard to get, but there is another one called the FORA, which is a near duplicate of it and also works quite well.

CYCLON 049

A rough rendering, drawn full size

Misc Exterior Specs:

Weight: 67 grams (Cox TeeDee 48 grams)

Radial backplate: 1.086 diameter

Mounting holes: 2.0 MM (.079)

Main cylinder diameter: .950

Top cylinder diameter: .945

Intake bore: .230

Prop stud: 4.0 MM (.157)

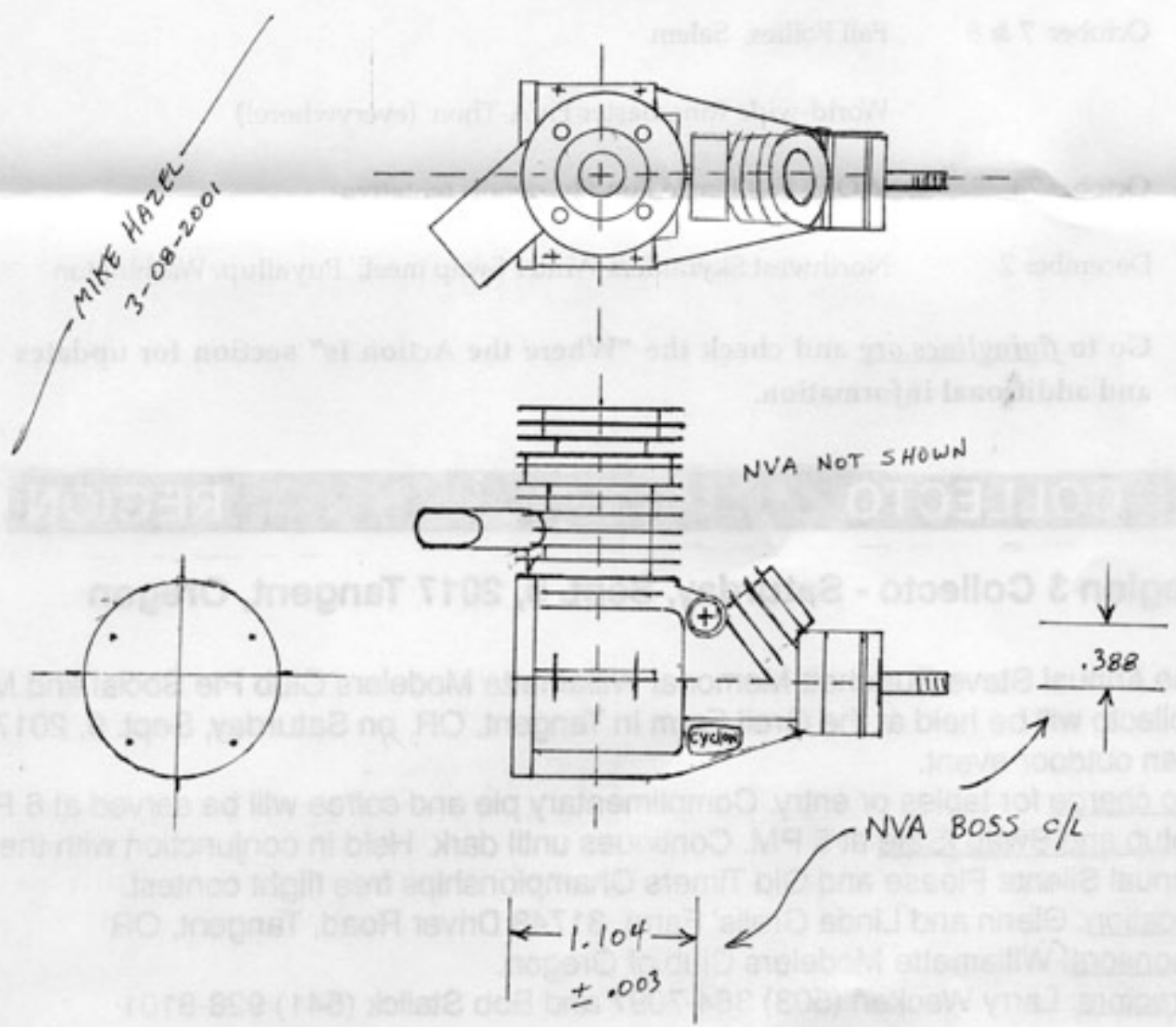

NORTHWEST CONTROL LINE CALENDAR

- September 2 Fun Fly at the Zoot Ranch (Mike's place)
(see flyer this issue)
- September 9 Willamette Modelers Club Swap Meet, Tangent, Oregon
(see flyer this issue)
- September 16 & 17 R.F. Stevenson Memorial Raider Roundup, Chehalis, Washington
(see flyer this issue)
- September 23 & 24 Northwest CL Speed Championships, Salem
(see flyer this issue)
- October 7 & 8 Fall Follies, Salem
- World-wide Ringmaster FlyA-Thon (everywhere!)
- October 28 WOLF Fall Finale Fun Fly, details tentative
- December 2 Northwest Skyraiders Winter Swap meet, Puyallup, Washington

Go to flyinglines.org and check the "Where the Action Is" section for updates and additional information.

COLLECTO

REGION

3

Region 3 Collecto - Saturday, Sept. 9, 2017 Tangent, Oregon

The Annual Steve Burtchett Memorial Willamette Modelers Club Pie Social and MECA Collecto will be held at the Grell Farm in Tangent, OR on Saturday, Sept. 9, 2017. This is an outdoor event.

No charge for tables or entry. Complimentary pie and coffee will be served at 6 PM.

Setup and Swap /Sale at 5 PM. Continues until dark. Held in conjunction with the Annual Silents Please and Old Timers Championships free flight contest.

Location: Glenn and Linda Grells' Farm, 31748 Driver Road, Tangent, OR

Sponsors: Willamette Modelers Club of Oregon.

Directors: Larry Wacken (503) 364-7097 and Bob Stalick (541) 928-8101

Family Fun Fly & Picnic at Mike Hazel's Zoot Ranch

Saturday, September 2nd, 2017
Activity starts at 10 AM, stay as late as you wish

Picnic:

BBQ lunch served at about 1:00
Burgers, hot dogs, and beverages provided
(table service also provided)
Please bring one side dish to share:
such as veggie or fruit plate, salad, chips,
beans, or dessert, etc.

Flying:

One grass circle with a practical max line length of 65 feet.
(please, no really loud high performance stuff!)

What to Bring:

Planes to fly
Picnic side dish
Lawn Chair

How to Get There:

The ranch is located about 20 miles east of Salem off Hwy 22
For directions: zzelspeed@aol.com or 503-871-1057

Please let us know if you are coming so we can plan appropriately

The Northwest Skyraiders Present
**The R.F. Stevenson Memorial
RAIDER ROUNDUP 2017**

September 16th and 17th, 2017
Chehalis-Centralia, WA Airport

See Accessory Instructions for directions, lodging, food

SCHEDULE

SATURDAY, September 17th:

10:00 am Old Time Stunt
following OT Classic Stunt
following Classic Profile Stunt
All Day NW Sport 40 Carrier

SUNDAY, September 18th:

9:00 am Precision Aerobatics:
Beginner skill class
Intermediate skill class
Advanced skill class
Expert skill class
9:00 am 80 MPH Combat, $\frac{1}{2}$ A Combat

All events are Junior-Senior-Open classes combined.

The Skyraiders will provide Classy Awards through 3rd place for each event.

Registration is from 8:00 am until start of event.

Sr and Open: \$20 for first event, \$10 for each additional event,
\$40 maximum (US Funds).....JUNIORS FREE!

AMA or MAAC Membership is required of all participants and mechanics.

AMA membership is available at registration.

For information contact Howard Rush, (425) 746-5997, hmrush@comcast.net



NORTHWEST CONTROL LINE SPEED CHAMPIONSHIPS

SEPTEMBER 23 & 24, 2017
SALEM, OREGON

THE DETAILS

A.M.A. SANCTION #17/1542

EVENTS: ALL A.M.A. AND NORTHWEST SPEED EVENTS PLUS F2A

CONTEST SITE IS THE BILL RIEGEL MODEL AIRPARK
AT THE SALEM AIRPORT

CONTEST HOURS: SATURDAY 10 - 5, SUNDAY 9 - 3:30

ENTRY FEE IS \$20 FOR ANY NUMBER OF EVENTS
HALF PRICE FOR N.A.S.S. MEMBERS
NO PRIZES, FLY FOR FAME AND GLORY

CONTACT: MIKE HAZEL, 503-871-1057, OR ZZCLSPEED@AOL.COM

